

ANDREWS PRODUCTS, INC.

431 Kingston Ct.
Mt. Prospect, IL USA 60056
847-759-0190 (phone)
847-759-0848 (fax)
www.andrewsproducts.com

Installation Instructions: Chain Drive Cams 1999-2006 Twin Cam (except '06 Dyna)

- A. We recommend that you read the factory service manual and follow all proper procedures for camshaft removal and replacement. The procedure for retracting and releasing the two sprocket chain tensions is especially important.
- B. Andrews Products makes heat treated, splined 34 tooth sprockets which are longer than stock H/D sprockets. The part number for the Andrews Products sprocket is 288015.
 1. All Andrews production Twin 88 cams are made with stock size lobe base circles so stock pushrods will be the correct length. If you are going to use the original pushrods, removing the fuel tank(s) and rocker boxes will be necessary. Mark the pushrods so they can be replaced into their original locations. (Not all stock pushrods are the same length).
 2. If you want to save installation time (and not remove fuel tanks and rocker arms), EZ-install pushrods are available from Andrews Products in either aluminum or chrome moly steel. If you are going to use EZ-install pushrods, stock pushrods can be cut with bolt cutters and then removed (in two pieces). Part numbers for EZ-install pushrods are: 292188 for aluminum and 292088 for steel pushrods.
 3. Remove the 10 bolts holding outer cam cover. When this cover is reinstalled later, there is a specific tightening sequence and torque setting for these 10 bolts.
 4. Before proceeding further, put the transmission in 4th or 5th gear. With spark plugs removed (no resistance from compression pressure), position the engine (by turning rear wheel) so camshaft timing marks are aligned. This will simplify installation of new cams.
 5. Following the factory service manual, the outer chain tension shoe must now be retracted. This can be done with H/D tool set (part number H/D-42313, cam chain tension unloader with retention pins).
 6. Remove the retaining bolt holding the crankshaft sprocket and the retaining bolt holding the rear camshaft sprocket. This can be done with H/D tool set (part number H/D-42314, crankshaft/camshaft sprocket locking tool). It is well worth the cost.
 7. Remove the cam support plate. All four oil pump retaining bolts must be loosened to permit correct oil pump rotor alignment at time of reassembly after the cam support plate is in place.
 8. With the cam support plate removed, the interior cam chain tensioner can be retracted and locked with the unloader tool. This retaining lock pin should not be removed until the cam support plate has been reinstalled back into the engine.
 9. If you are converting the rear camshaft to a roller bearing, see the diagram on the next page.
10. Fitting new 34T sprockets: Three shims and one "O" ring are supplied in each Andrews 34 tooth sprocket kit. The three shims are; .005", .010" and .020". Andrews 34 tooth sprockets are machined to approximately .690 length. After a trial assembly, alignment of crankshaft sprocket and cam sprocket must be checked and adjusted with shims if necessary. See factory manual for proper procedure. Make sure all timing marks are aligned before proceeding! (See figures 1 and 2, next page).
11. When reinstalling sprocket retaining bolts, use Loctite retaining compound to secure the bolt threads. The sprocket locking tool can be used here. Bolt torque should not exceed 25 ft-lbs for 5/16 x 18 bolts. Bolt torque for splined rear camshafts (3/8 x 24 bolt) should not exceed 35 ft-lbs. Please note that whether your camshaft uses 5/16 bolts (key drive camshafts) or 3/8 bolts (spline drive camshafts), the bolts must be rated as grade 8. (All grade 8 bolts have a 6 pointed star symbol on the top of the bolt heads).
12. Reinstall the outer cam cover with the 10 cover bolts. Cover bolts are to be tightened to a torque specification of 90-120 in-lbs. The service manual shows the correct tightening sequence.
13. EZ-install pushrods are made with 2 long (exhaust), and 2 short (intake) rods. To install, adjust pushrod to shortest length, then position in engine, rocker arm end first. Swing the lower end into lifter. Lengthen pushrod adjuster until free play is gone. Adjust pushrod 3.5-4 full turns longer (21-24 flats) and tighten locknut. Wait until hydraulic unit bleeds down and repeat procedure on next pushrod. When adjusting pushrods, make sure that cam lobe for that pushrod is on low lift point. Lifter housing covers can be temporarily removed to gain another 1/4 inch of clearance. Shorter pushrod cover tubes are available from HD. They will make the pushrod installation and adjustment much easier. Part numbers are: 17938-83 and 17634-99. You will need 4 of each part number to install a complete set.
14. For engines with stock pistons and stock heads, TW21, TW26A, TW31S and TW37B cams will bolt in without head work. TW50 and TW54 cams need piston to valve clearances and valve to valve clearances checked. TW54, TW55 and TW60A cams need .620 minimum valve travel and .060 minimum piston to valve clearance. With Andrews Products high lift steel collars (part# 293115 ; includes 4 pcs), setting valve spring travel for either of these two cams will be easier.
15. Final tuning of carburetors with bigger cams sometimes requires re-jetting. For stock H/D Keihin CV carbs and TW26A or TW37B cams, #48 slow jets and #175 main jets will be a reasonable starting point. When tuning engines, always remember that your personal safety is the most important consideration.
16. Fuel injected engines can benefit from remapping the fuel control which can be done most efficiently with a dynamometer.

Andrews Products: Twin Cam 88 Chain Drive Camshaft Timing

Andrews#	Grind	Timing*	Duration*	Lift	Springs	TDC Lift	Spring Travel
-----	Stock (A) 99 (carb)	-02/38 42/-03	216 219	.473 .473	Stock -	.072 .110	Stock Stock
-----	Stock (B) 99 (fuel inj)	02/34 42/-03	216 219	.473 .473	Stock -	.087 .110	Stock Stock
288112	TW12	02/34 40/02	216 220	.489 .489	Stock -	.091 .106	Stock Stock
288121	TW21	10/30 40/08	220 228	.498 .498	Stock -	.134 .121	Stock Stock
288126	TW26A	11/35 41/09	226 230	.490 .490	Stock -	.138 .120	Stock Stock
288131	TW31S	10/46 52/08	236 240	.510 .510	Stock -	.131 .120	Stock Stock
288137	TW37B	18/38 46/14	236 240	.510 .510	Stock -	.174 .148	Stock Stock
288154	TW54	16/42 43/15	238 238	.555 .555	Hi-lift -	.165 .158	.625 .625
288150	TW50	20/48 54/18	248 252	.510 .510	Stock -	.184 .168	Stock Stock
288155	TW55	22/46 52/20	248 252	.550 .550	Hi-lift -	.197 .181	.620 .620
288160	TW60A	24/56 58/22	260 260	.560 .560	Hi-lift -	.205 .192	.620 .620

*Timing and duration listed for .053 cam lift

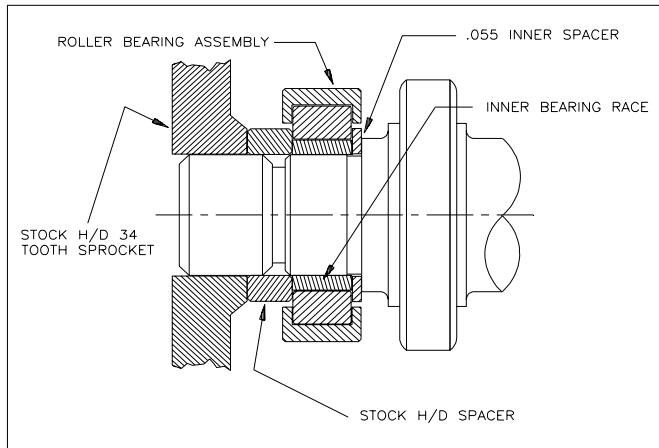

Figure 1

Figure 1 applies to engines with stock H/D 34 tooth drive sprockets and stock H/D spacers.

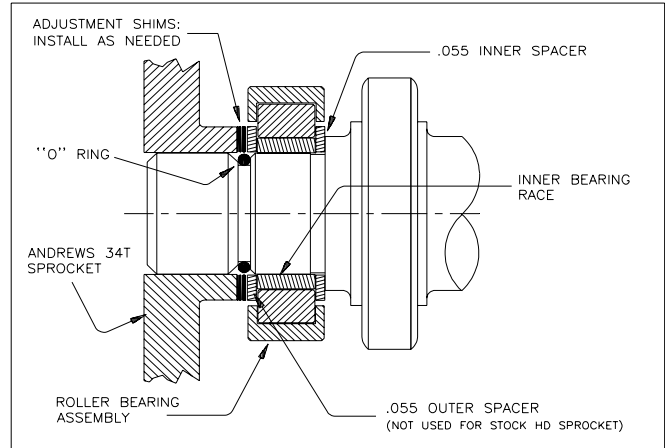

Figure 2

Figure 2 applies to installations with Andrews Products 34 tooth sprockets which uses **two** .055 thick spacers.

IMPORTANT NOTES:

Engines with **stock H/D splined sprockets** should be able to re-use the original sprocket spacer (.230 to .270 long) which was previously installed in the engine. If you need more shims for a larger range of adjustment, 5 piece packs are available (.287 to .327) from H/D. The H/D part number for the spacer package is:
25446-99-SUB.

If you are installing an **Andrews Products 34 tooth** steel sprocket, part numbers are:
34 tooth sprocket: 288015
.055 spacer washer: 301130
3 piece shim pack: 301120