

**ANDREWS**

**EZCAM**

## Complete Camshaft Measurement and Analysis



Model M52

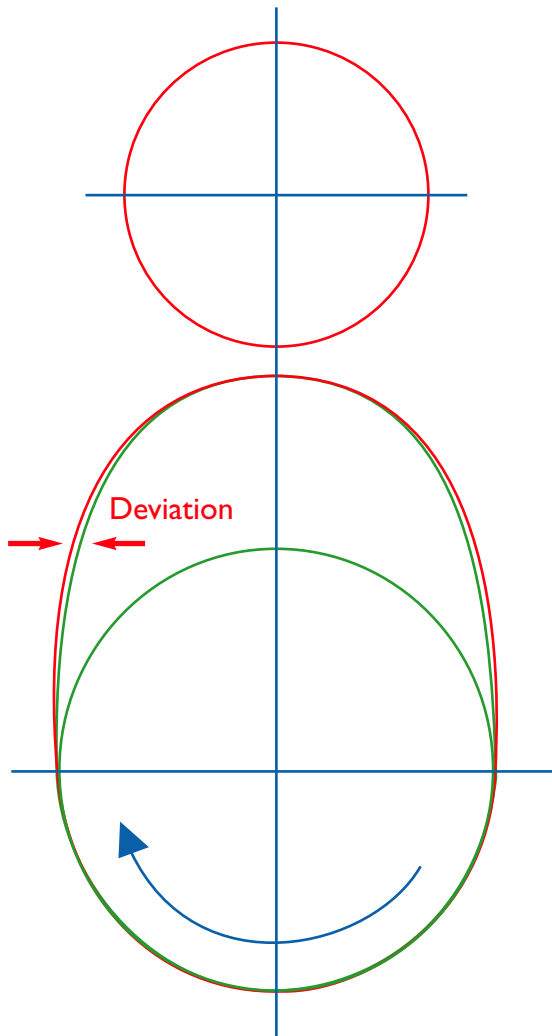
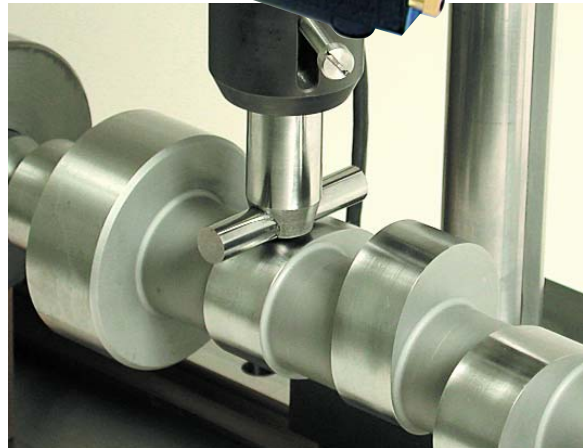

### KEY FEATURES:

- Complete lobe measurement, graphical display and analysis of: lift, velocity, acceleration, jerk (3rd derivative), radius of curvature, pressure angle
- Lobe data corrected to zero base circle runout
- Angular position listings for all lobe tip angles
- Compare measured data and design lift data profiles in graphic and numeric modes
- Screen graphic displays for all motion curves
- Printed reports of screen graphics and tabular data
- Compare base circle radius, runout and lobe tip angles to design data showing tolerance limits
- Inch or metric data input and output
- EZCAM programs run under Windows
- Computer controlled camshaft rotation on motorized versions
- Heidenhain™ sensors and data collection hardware
- Only one size measuring probe needed, regardless of engine follower size
- User defined set up included for other languages

# EZCAM

With an EZCAM, you can inspect one single lobe, two lobes (intake and exhaust) or an entire camshaft. In addition to data for all cam lobes, you get ALL of the lobe tip angles too. Captured data is saved to a file for later study. Instrument resolution is .10 degrees and .000005 inches. Cam lobe data is taken by rotating the camshaft manually or with a motorized spindle. Measurements can be taken using a round or flat measuring probe. Data is then mathematically converted to the correct engine follower type and size.

A complete mathematical analysis is then performed which includes one degree output for lift, velocity, acceleration, jerk and radius of curvature. Data smoothing can also be performed on screen. Output options include data analysis to the screen or a printer. Original data can be analyzed, smoothed and corrected for shaft eccentricity and base circle runout, and then saved to disk for easy recall.

Shown below are two drop-down menus of keyboard command functions available from the main graphic display screen.

Main graphic display screen shows all motion curves and numerical summary for one cam lobe.

The screenshot displays the EZCAM software interface. At the top, the title bar reads "EZCam Windows Version 1.0; Build Date: Oct 18 2000 11:47:57; EZCam". Below the title bar is a menu bar with "File", "Edit", "View", "Function", "Alt", "Setup", "Utility", and "Help". A toolbar contains icons for various functions and function keys F1 through F12. The main area is a graph with a blue background and white grid. The x-axis ranges from -18 to 18, and the y-axis ranges from -10.0000 to 10.0000. Several curves are plotted: a red curve (lift), a purple curve (velocity), a yellow curve (acceleration), and a green curve (base circle runout). Below the graph is a summary table with columns for "Overall Summary", "Summary", "Text", "Open Output:", and "Close Output:". The "Overall Summary" table lists parameters like Scaling, Follower Radius, Maximum Lift, Acceleration At Tip, Base Circle Radius, Tip Angle, Eccentricity, Eccentricity Angle, Runout, Smoothing Passes, Total Passes, and Phase Error. The "Summary" table lists Check Ht, Open, Close, and Total values. The "Text" table lists Max. Velocity, Max. Acceleration, Min. Acceleration, Max. Jerk, Min. Jerk, Max. Pressure Angle, Min + Radius Of Curvature, Min - Radius Of Curvature, Area, Event Length, and Max Profile Error. The "Open Output:" and "Close Output:" tables list values at specific angles. At the bottom, there is a "Data Path" section with fields for Config File, Data File, and Target File. To the right of the graph, there are two drop-down menus. The top one is labeled "Alt" and lists functions like "Display Measured vs Target Difference Data", "Display Smoothing Error", "Expand/Contract Main Graph", etc. The bottom one is labeled "Function" and lists functions like "Recalculate", "Display/Remove Jerk Curve", "Save Smoothed Lift Data To Target/Open/Close Files", etc.

Overall Summary	Summary	Text	Open Output:	Close Output:
Scaling: 1.00	Check Ht: 0.3000	Max. Velocity: 0.008148	At -56.0: 0.008155	At 55.0: 0.008155
Follower Radius: 0.3750	Open: 51.12	Max. Acceleration: 0.000209	At -81.0: 0.000209	At 81.0: 0.000209
Maximum Lift: 0.540112	Close: 63.51	Min. Acceleration: -0.000202	At -3.0: -0.000206	At 2.0: -0.000206
Acceleration At Tip: -0.000205	Total: 204.40	Max. Jerk: 0.000017	At -103.0: 0.000018	At 56.0: 0.000018
Base Circle Radius: 0.6988	0.2000: 63.57	Min. Jerk: -0.000017	At -57.0: -0.000015	At 99.0: -0.000015
Tip Angle: 90.04	0.0500: 78.47	Max. Pressure Angle: 19.354330	At -58.0: 19.352688	At 58.0: 19.352688
Eccentricity: 0.00027	0.0200: 90.05	Min + Radius Of Curvature: 0.699062	At -137.0: 0.696985	At 15.0: None
Eccentricity Angle: 266.15	0.0100: 106.54	Min - Radius Of Curvature: None	At -15.0: None	At 15.0: None
Runout: 0.00035	0.0050: 121.65	Area: 30.21	At 18°: 0.000161	At 18°: 0.000161
Smoothing Passes: 0		Event Length: 138		
Total Passes: 0		Max Profile Error: 0.000159		
Phase Error: -0.027				

## MAIN GRAPHIC DISPLAY SCREEN

EZCAM's main screen showing lift, velocity, acceleration, jerk and radius of curvature for opening and closing sides of one lobe. Lift data is automatically saved to disk for future reference. Green curve represents base circle runout. One size inspection probe can be used for any cam lobe. Program will mathematically correct final data for whatever size engine follower is specified.

Number Of Smoothing Passes	0	Eccentricity Magnitude	0.00045
Acceleration At Tip	-0.000231	Eccentricity Angle	40.66
Maximum Lift	0.410066	Runout	0.00072
Base Circle Radius	0.5062	Phase Error	-0.075
Follower Radius	0.3750		
Tip Angle	323.03		

Output	Opening Side	Closing Side	
Max Velocity	0.008236	0.008285	
Acceleration Max	0.000298	0.000319	
Acceleration Min	-0.000219	-0.000255	
Jerk Max	0.000026	0.000035	
Jerk Min	-0.000026	-0.000037	
Max Pressure Angle	24.370966	24.309986	
- Radius of Curvature Min	0.427408	0.407820	
+ Radius of Curvature Min	None	None	
Total Area	18.44	18.37	Duration
Check Height 1: 0.3000	32.88	32.49	130.74
Check Height 2: 0.2000	46.29	45.69	183.96
Check Height 3: 0.1000	58.79	58.28	234.16
Check Height 4: 0.0500	66.80	66.68	266.97

**TABULAR RESULTS**  
Data from one cam lobe can be viewed in the form of this table.

**LIFT CURVE DEVIATION PLOTS**  
Below: for comparing measured data with original design target data, a lift curve deviation plot can be displayed. All base circle runout has been removed prior to this comparison. Corrected, re-centered data can then be viewed on screen, printed or saved to disk.

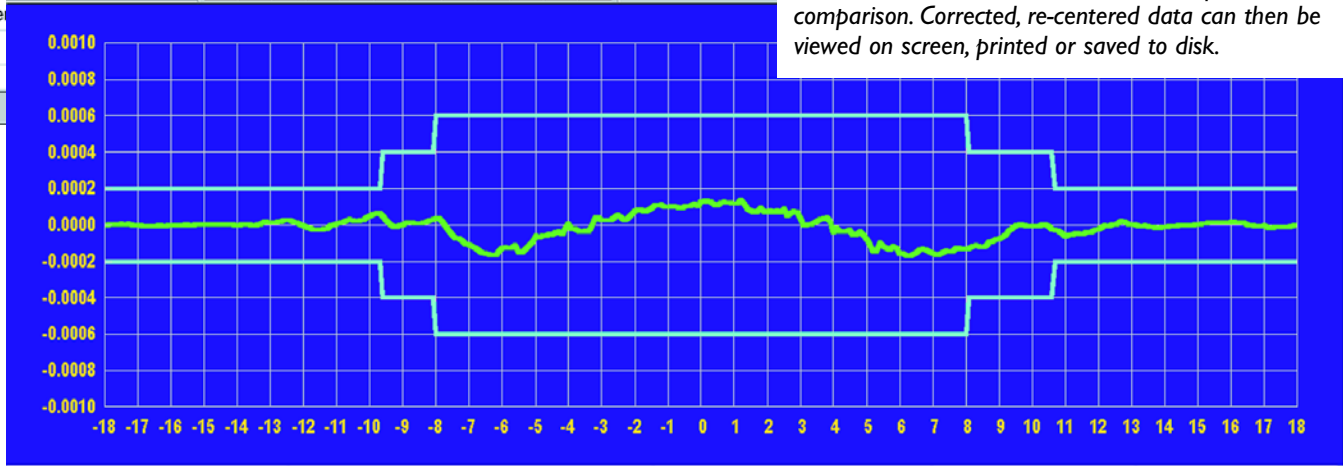

Results Summary	Duration Summary	Min/Max Results	Open Side:	Close Side:
Scaling: 1.00	Check Ht: 0.3000	Max. Velocity: 0.008137	At -53.0	0.008140 At 52.0
Follower Radius: 0.3750	0.2000	Max. Acceleration: 0.000206	At -91.0	0.000205 At 86.0
Maximum_Lift: 0.540103	0.1000	Min. Acceleration: -0.000204	At -13.0	-0.000208 At 13.0
Acceleration At: -0.000204	0.0500	Max. Jerk: 0.000017	At -103.	0.000019 At 51.0
Base Circle Radius: 0.6987	0.0200	Min. Jerk: -0.000016	At -122.	-0.000018 At 95.0
Tip Angle: 0.03	0.0100	Max. Pressure Angle: At -60.0		19.391513 At 60.0
Eccentricity: 0.00014	0.0050	Min + Radius Of Curvature: 0.693730	At -137.	0.698871 At
Eccentricity: 144.37		Min - Radius Of Curvature: None	At -15.0	None At 15.0
Runout: 0.00010		Area: 30.21		30.11
Smoothing: 0		Event Length: 138		137
Total Passes: 0		Max Profile Error: -0.000164	At -62°	-0.000168 At 64°
Phase Error: -0.023				
<b>Data File Paths</b>		Units Mode: Inch	Zoom	
Config File: CALRAD\F360R540.CFG		Rotation: Reverse	Next Lobe	
Data File: CALRAD\FCALRAD2.S01		Lobe_Type: Exhaust	Previous Lobe	
Target File: CALRAD\360R540.TGT		Cylinder: 1		

*EZCAM with precision roller  
V-block bearing supports  
with motor controller.*

*All EZCAM systems use precision monorail linear  
guideways for accurately positioning the Heidenhain  
probe at the desired cam lobe. Monorails provide  
great accuracy and rigidity while allowing positioning  
of the probe with a light hand motion.*

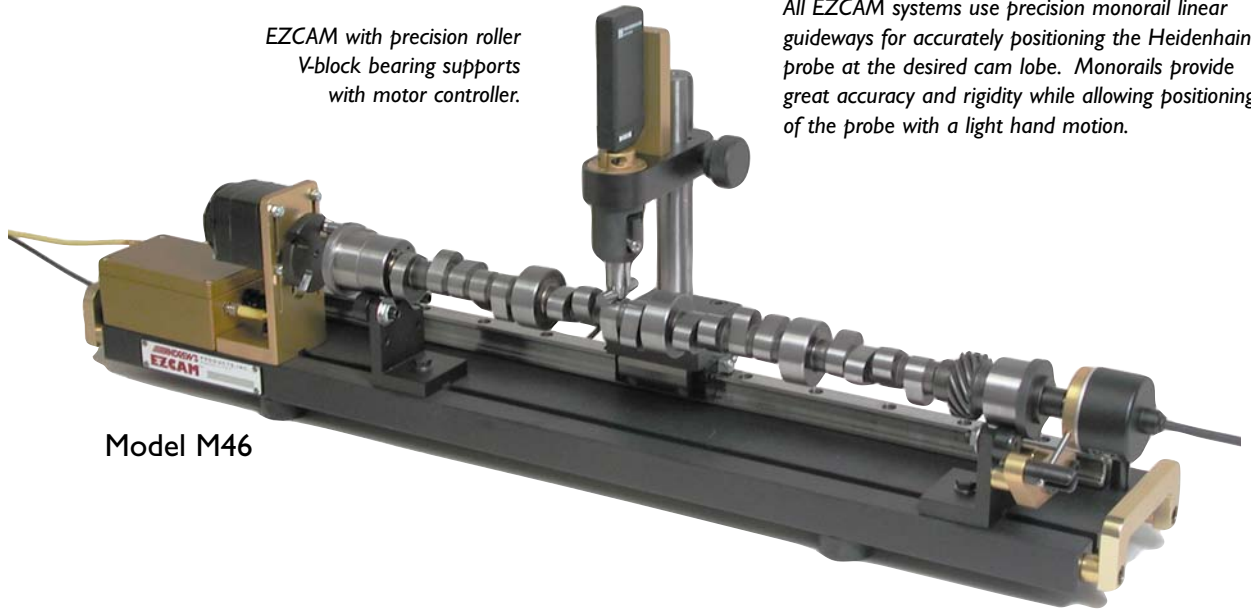

Model M46

*EZCAM instrument  
for small engine  
camshafts (shown  
here with a 10" long  
camshaft).*

*EZCAM system with super precision  
live center headstock, dead center  
tail stock and tungsten carbide  
tipped centers. Headstocks are  
made by Andrews Products and  
have maximum runouts not  
exceeding .000060 (60 millionths  
inches) or .0015 mm.*

**Available with  
round or flat  
follower probes**

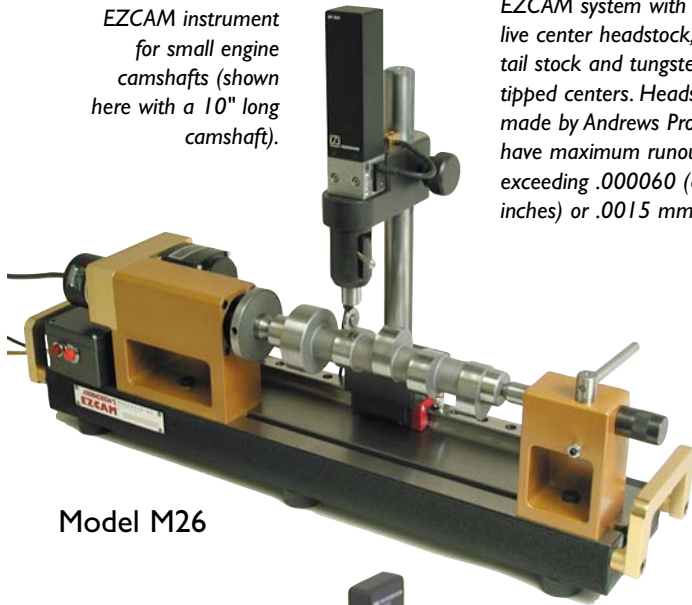

Model M26



*Shown below is the entry level EZCam system  
with V-block bearing supports and manual  
camshaft rotation. All EZCam systems are  
available with various types of followers,  
including easily replaceable tungsten carbide  
bars, and tungsten carbide rollers.*

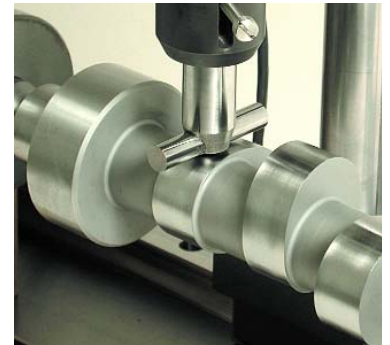

Model M25

EZCam Windows Version 1.1. Build Date: Oct 20 2000 13:10:36. EZCam Development Computer. Serial#: 1000. Copyright © 1997-2000. Andrews Products, Inc.

File Edit View Function Alt Setup Utility Help

F1 F2 F3 F4 F5 F9 F10 F11 F12

410TEST\CENTERED\410STRTA.S01

Data Opening Side Closing Side

Complete tabular results for all motion curves on each cam lobe.

Angle	Input Lift	Smoothed Lift	Smoothed Change	Velocity	Acceleration	Jerk	Pressure Angle
0	0.410041	0.410041	0.000000	0.0000324	-0.0001871	-0.0000278	0.4999280
1	0.409987	0.409987	0.000000	0.0001921	-0.0001754	-0.0000087	0.5179357
2	0.409685	0.409685	0.000000	0.0003865	-0.0001899	0.0000129	0.4954102
3	0.409181	0.409181	0.000000	0.0005986	-0.0002145	0.0000161	0.4598182
4	0.408492	0.408492	0.000000	0.0008121	-0.0002142	0.0000052	0.4597450
5	0.407565	0.407565	0.000000	0.0010228	-0.0002134	-0.0000022	0.4601452
6	0.406431	0.406431	0.000000	0.0012370	-0.0002115	-0.0000026	0.4619817
7	0.405098	0.405098	0.000000	0.0014461	-0.0002111	-0.0000008	0.4615374
8	0.403546	0.403546	0.000000	0.0016574	-0.0002108	-0.0000012	0.4608032
9	0.401775	0.401775	0.000000	0.0018704	-0.0002091	-0.0000020	0.4619049
10	0.399804	0.399804	0.000000	0.0020834	-0.0002074	-0.0000028	0.4630166
11	0.397624	0.397624	0.000000	0.0022964	-0.0002057	-0.0000036	0.4641283
12	0.395244	0.395244	0.000000	0.0025094	-0.0002040	-0.0000044	0.4652400
13	0.392664	0.392664	0.000000	0.0027224	-0.0002023	-0.0000052	0.4663517
14	0.389889	0.389889	0.000000	0.0029354	-0.0002006	-0.0000060	0.4674634
15	0.386871	0.386871	0.000000	0.0031484	-0.0001989	-0.0000068	0.4685751
16	0.383688	0.383688	0.000000	0.0033614	-0.0001972	-0.0000076	0.4696868
17	0.380287	0.380287	0.000000	0.0035744	-0.0001955	-0.0000084	0.4707985
18	0.376685	0.376685	0.000000	0.0037874	-0.0001938	-0.0000092	0.4719102
19	0.372883	0.372883	0.000000	0.0040004	-0.0001921	-0.0000100	0.4730219
20	0.368860	0.368860	0.000000	0.0042134	-0.0001904	-0.0000108	0.4741336
21	0.364657	0.364657	0.000000	0.0044264	-0.0001887	-0.0000116	0.4752453
22	0.360262	0.360262	0.000000	0.0046394	-0.0001870	-0.0000124	0.4763570

Measure Cam Lift Lobe

Information

Cam Rotation:  Clockwise  Counter Clockwise

Part Number: calrad  
Lot Number: 137  
FileName: dpo  
Sample Number: 42

Probe Radius (Inches): 40.0000  
Reference Radius (Inches): 0.3750

Dialog for measuring all lobes on a camshaft.

Messages

FILE NAME IS: calrad\137\dpo42.S01  
POSITION PROBE ON LOBE 01, PRESS ENTER:  
ROTATE CAMSHAFT ONE REVOLUTION:  
TASK COMPLETE FOR LOBE 01

ENTER LOBE NUMBER TO MEASURE: (LOBE NO.=02)  
FILE NAME IS: calrad\137\dpo42.S02  
POSITION PROBE ON LOBE 02, PRESS ENTER:  
ROTATE CAMSHAFT ONE REVOLUTION:  
TASK COMPLETE FOR LOBE 02

ENTER LOBE NUMBER TO MEASURE: (LOBE NO.=03)  
FILE NAME IS: calrad\137\dpo42.S03  
POSITION PROBE ON LOBE 03, PRESS ENTER:  
ROTATE CAMSHAFT ONE REVOLUTION:  
TASK COMPLETE FOR LOBE 03

ENTER LOBE NUMBER TO MEASURE: (LOBE NO.=04)

Current Lobe Number: 3

Proceed

Press Esc Key To End Measurements

Date File Name: calrad\137\dpo42

Cancel

A polar plot showing measured deviation versus design tolerances.

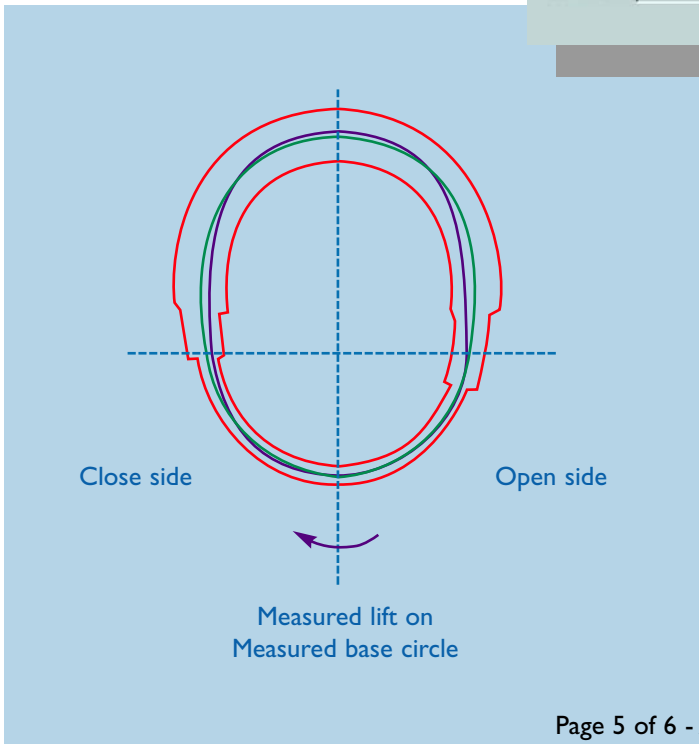

Green trace is the target lift.  
Red trace is the tolerance limit.  
Magenta trace is a magnified view showing deviations of measured lobe data compared to target data.

# EZCAM



## General Specifications

	Minimum/Maximum Cam Lengths	Maximum Cam Weight	Instrument Base Material	Instrument Base Thickness	Instrument Length	Instrument Weight Approx.
M25 Manual Vblock system . . . . .	4-25 . . . . .	10# . . . . .	Aluminum . . . . .	0.75 inch . . . . .	25 inches . . . . .	20#
M34 Manual Vblock system . . . . .	4-34 . . . . .	10# . . . . .	Aluminum . . . . .	1.25 inch . . . . .	34 inches . . . . .	50#
M46 Motorized Vblock system . . . . .	4-34 . . . . .	10# . . . . .	Aluminum . . . . .	1.50 inch . . . . .	46 inches . . . . .	75#
M26 Motorized Center system . . . . .	1-12 . . . . .	20# . . . . .	Cast iron . . . . .	2.00 inch . . . . .	26 inches . . . . .	125#
M52 Motorized Center system . . . . .	1-36 . . . . .	30# . . . . .	Steel . . . . .	2.00 inch . . . . .	52 inches . . . . .	200#
M78 Motorized Center system . . . . .	1-60 . . . . .	50# . . . . .	Steel . . . . .	3.00 inch . . . . .	78 inches . . . . .	400#

NOTE: Standard system includes: 1.0 inch (25.4 mm) maximum probe travel above camshaft base circle.  
 Flanges and gears on camshafts which exceed 1.9 inch (48 mm) diameter may require longer probe travel.  
 Cam lobes having maximum lift greater than 1.00 inch may also require longer probe travel.

Additional probe travel options are as follows:

- 1.5 inch (38.1 mm) maximum probe travel (above the base circle)
- 2.0 inch (50.00 mm) maximum probe travel (above the base circle)
- 2.5 inch (60.00 mm) maximum probe travel (above the base circle)

## Accuracy and Resolution

	System Lift Accuracy	System Angle Accuracy	Repeatability Lift	Repeatability Angle	Encoder Resolution Lift	Encoder Resolution Angle	Report Decimal Lift	Report Decimal Angle
M25 Manual Vblock system . . . . .	+/- 0.002 in . . . . .	+/- 0.50 deg. . . . .	0.0007 . . . . .	0.2 . . . . .	0.00005 . . . . .	0.1 . . . . .	5 digits . . . . .	2 digits
M34 Manual Vblock system . . . . .	+/- 0.001 in . . . . .	+/- 0.25 deg. . . . .	0.0003 . . . . .	0.1 . . . . .	0.000005 . . . . .	0.1 . . . . .	5 digits . . . . .	2 digits
M46 Motorized Vblock system . . . . .	+/- 0.001 in . . . . .	+/- 0.25 deg. . . . .	0.0003 . . . . .	0.1 . . . . .	0.000005 . . . . .	0.1 . . . . .	5 digits . . . . .	2 digits
M26 Motorized Center system . . . . .	+/- 0.0005 in . . . . .	+/- 0.10 deg. . . . .	0.0001 . . . . .	0.02 . . . . .	0.000005 . . . . .	0.1 . . . . .	6 digits . . . . .	3 digits
M52 Motorized Center system . . . . .	+/- 0.0005 in . . . . .	+/- 0.10 deg. . . . .	0.0001 . . . . .	0.02 . . . . .	0.000005 . . . . .	0.1 . . . . .	6 digits . . . . .	3 digits
M78 Motorized Center system . . . . .	+/- 0.0005 in . . . . .	+/- 0.10 deg. . . . .	0.0001 . . . . .	0.02 . . . . .	0.000005 . . . . .	0.1 . . . . .	6 digits . . . . .	3 digits

## Complete system includes:

- EZCAM instrument base and hardware
- Two Heidenhain™ measuring probes with PCI data capture card (Angle and lift encoders)
- Computer with Windows and encoder/motor drive interfaces. (Monitor must be customer supplied.)
- EZCAM Windows software installed and ready to run
- Documentation for EZCAM setup and operation
- Calibration camshaft and driver



NEW ADDRESS & PHONE AS OF SEPTEMBER 1, 2002:  
 431 Kingston Court • Mount Prospect, IL 60056 USA • Phone: 847-759-0190 • Fax: 847-759-0848  
 www.andrewsproducts.com • Email: ezcaml@andrewsproducts.com